

Selecting Cables

● Cables Connections

● Standard Wiring (Max. encoder cable length: 20 m)

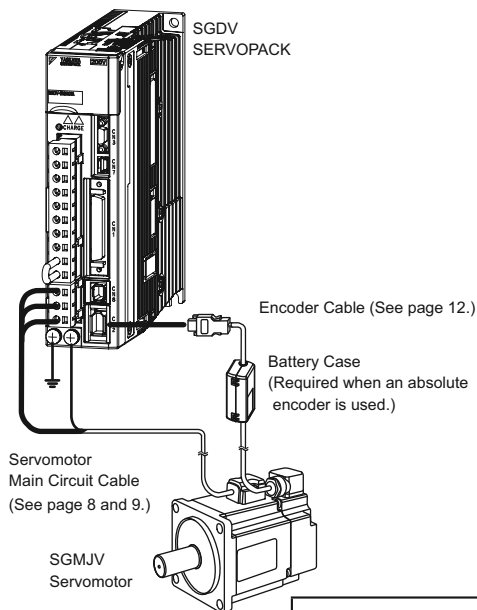

● Encoder Cable Extension from 30 to 50 m

(See page 14.)

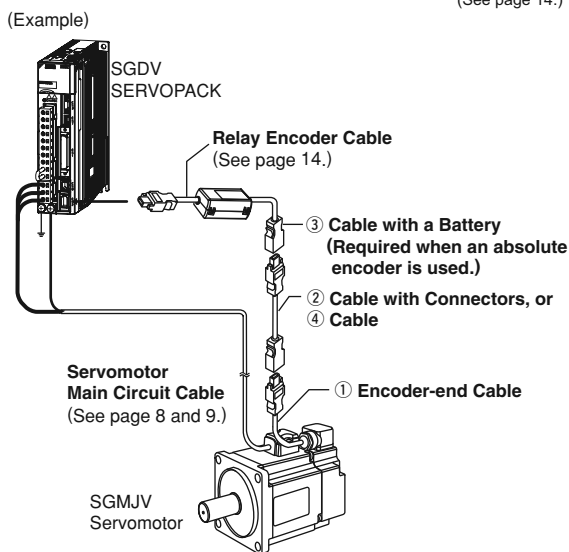

⚠ CAUTION

- Separate the servomotor main circuit cable from the I/O signal cable and encoder cable at least 30 cm, and do not bundle or run them in the same duct.
- When the cable length exceeds 20 m, be sure to use a relay encoder cable.
- When the main circuit cable length exceeds 20 m, note that the intermittent duty zone of the Torque-Motor Speed Characteristics will shrink as the line-to-line voltage drops.

● Servomotor Main Circuit Cable

Name	Servomotor Rated Output	Length	Order No.		Specifications	Details
			Standard Type	Flexible Type*		
For Servomotor without Holding Brakes	50 to 100 W	3 m	JZSP-CSM01-03-E	JZSP-CSM21-03-E		(1)
		5 m	JZSP-CSM01-05-E	JZSP-CSM21-05-E		
		10 m	JZSP-CSM01-10-E	JZSP-CSM21-10-E		
		15 m	JZSP-CSM01-15-E	JZSP-CSM21-15-E		
		20 m	JZSP-CSM01-20-E	JZSP-CSM21-20-E		
		30 m	JZSP-CSM01-30-E	JZSP-CSM21-30-E		
		40 m	JZSP-CSM01-40-E	JZSP-CSM21-40-E		
		50 m	JZSP-CSM01-50-E	JZSP-CSM21-50-E		
	200 to 400 W	3 m	JZSP-CSM02-03-E	JZSP-CSM22-03-E		
		5 m	JZSP-CSM02-05-E	JZSP-CSM22-05-E		
		10 m	JZSP-CSM02-10-E	JZSP-CSM22-10-E		
		15 m	JZSP-CSM02-15-E	JZSP-CSM22-15-E		
		20 m	JZSP-CSM02-20-E	JZSP-CSM22-20-E		
		30 m	JZSP-CSM02-30-E	JZSP-CSM22-30-E		
		40 m	JZSP-CSM02-40-E	JZSP-CSM22-40-E		
		50 m	JZSP-CSM02-50-E	JZSP-CSM22-50-E		
	750 W	3 m	JZSP-CSM03-03-E	JZSP-CSM23-03-E		
		5 m	JZSP-CSM03-05-E	JZSP-CSM23-05-E		
		10 m	JZSP-CSM03-10-E	JZSP-CSM23-10-E		
		15 m	JZSP-CSM03-15-E	JZSP-CSM23-15-E		
		20 m	JZSP-CSM03-20-E	JZSP-CSM23-20-E		
		30 m	JZSP-CSM03-30-E	JZSP-CSM23-30-E		
		40 m	JZSP-CSM03-40-E	JZSP-CSM23-40-E		
		50 m	JZSP-CSM03-50-E	JZSP-CSM23-50-E		

(Cont'd)

Selecting Cables

Name	Servomotor Rated Output	Length	Order No.		Specifications	Details
			Standard Type	Flexible Type*		
For Servomotor with Holding Brakes	50 to 100 W	3 m	JZSP-CSM11-03-E	JZSP-CSM31-03-E		(2)
		5 m	JZSP-CSM11-05-E	JZSP-CSM31-05-E		
		10 m	JZSP-CSM11-10-E	JZSP-CSM31-10-E		
		15 m	JZSP-CSM11-15-E	JZSP-CSM31-15-E		
		20 m	JZSP-CSM11-20-E	JZSP-CSM31-20-E		
		30 m	JZSP-CSM11-30-E	JZSP-CSM31-30-E		
		40 m	JZSP-CSM11-40-E	JZSP-CSM31-40-E		
	200 to 400 W	3 m	JZSP-CSM12-03-E	JZSP-CSM32-03-E		
		5 m	JZSP-CSM12-05-E	JZSP-CSM32-05-E		
		10 m	JZSP-CSM12-10-E	JZSP-CSM32-10-E		
		15 m	JZSP-CSM12-15-E	JZSP-CSM32-15-E		
		20 m	JZSP-CSM12-20-E	JZSP-CSM32-20-E		
		30 m	JZSP-CSM12-30-E	JZSP-CSM32-30-E		
		40 m	JZSP-CSM12-40-E	JZSP-CSM32-40-E		
	750 W	3 m	JZSP-CSM13-03-E	JZSP-CSM33-03-E		
		5 m	JZSP-CSM13-05-E	JZSP-CSM33-05-E		
		10 m	JZSP-CSM13-10-E	JZSP-CSM33-10-E		
		15 m	JZSP-CSM13-15-E	JZSP-CSM33-15-E		
		20 m	JZSP-CSM13-20-E	JZSP-CSM33-20-E		
		30 m	JZSP-CSM13-30-E	JZSP-CSM33-30-E		
		40 m	JZSP-CSM13-40-E	JZSP-CSM33-40-E		
Servomotor-end Connector Kit	50 to 100 W	JZSP-CSM9-1-E		Crimping Type (A crimp tool is required.)	(3)	
	200 to 400 W	JZSP-CSM9-2-E			(4)	
	750 W	JZSP-CSM9-3-E			(5)	
Cables	50 to 400 W	5 m	JZSP-CSM90-05-E	JZSP-CSM80-05-E		(6)
		10 m	JZSP-CSM90-10-E	JZSP-CSM80-10-E		
		15 m	JZSP-CSM90-15-E	JZSP-CSM80-15-E		
		20 m	JZSP-CSM90-20-E	JZSP-CSM80-20-E		
		30 m	JZSP-CSM90-30-E	JZSP-CSM80-30-E		
		40 m	JZSP-CSM90-40-E	JZSP-CSM80-40-E		
	750 W	5 m	JZSP-CSM91-05-E	JZSP-CSM81-05-E		(7)
		10 m	JZSP-CSM91-10-E	JZSP-CSM81-10-E		
		15 m	JZSP-CSM91-15-E	JZSP-CSM81-15-E		
		20 m	JZSP-CSM91-20-E	JZSP-CSM81-20-E		
		30 m	JZSP-CSM91-30-E	JZSP-CSM81-30-E		
		40 m	JZSP-CSM91-40-E	JZSP-CSM81-40-E		
		50 m	JZSP-CSM91-50-E	JZSP-CSM81-50-E		

*: Use flexible cables for movable sections such as robot arms.

(1) Wiring Specifications for Servomotors without Holding Brakes

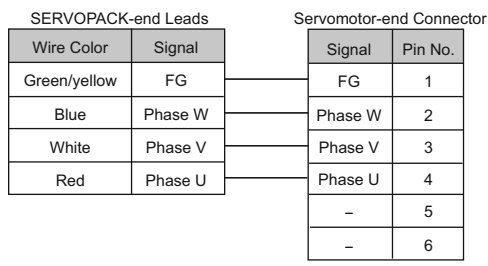

Note: This cable is not shielded.

(2) Wiring Specifications for Servomotor with Holding Brakes

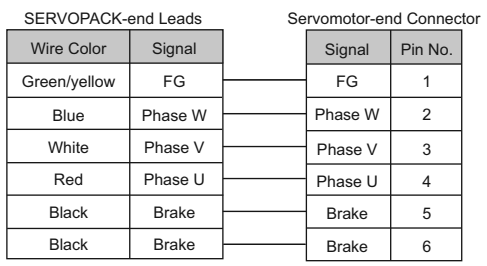

Note: No polarity for connection to a holding brake.
Note: This cable is not shielded.

Selecting Cables

(3) Servomotor-end Connector Kit Specifications: For 50 to 100 W Servomotors

Items		Specifications	External Dimensions mm
Order No.	JZSP-CSM9-1-E (Cables are not included.)		
Applicable Servomotors	SGMJV-A5A, -01A		
Manufacturer	J.S.T. Mfg. Co., Ltd.		
Receptacle	J17-06FMH-7KL-1-CF		
Electrical Contact	SJ1F-01GF-P0.8		
Applicable Wire Size	AWG20 to 24		
Outer Diameter of Insulating Sheath	1.11 dia. to 1.53 dia. mm		
Crimp Tool	Hand tool	YRS-8841	
	Applicator	APLMK SJ1F/M-01-08	
Mounting Screw	M2 Pan-head screw		
Applicable Cable Outer Diameter	7±0.3 dia. mm		

(4) Servomotor-end Connector Kit Specifications: For 200 to 400 W Servomotors

Items		Specifications	External Dimensions mm
Order No.	JZSP-CSM9-2-E (Cables are not included.)		
Applicable Servomotors	SGMJV-02A, -04A		
Manufacturer	J.S.T. Mfg. Co., Ltd.		
Receptacle	J27-06FMH-7KL-1-CF		
Electrical Contact	SJ2F-01GF-P1.0		
Applicable Wire Size	AWG20 to 24		
Outer Diameter of Insulating Sheath	1.11 dia. to 1.53 dia. mm		
Crimp Tool	Hand tool	YRS-8861	
	Applicator	APLMK SJ2F/M-01-08	
Mounting Screw	M2 Pan-head screw		
Applicable Cable Outer Diameter	7±0.3 dia. mm		

(5) Servomotor-end Connector Kit Specifications: For 750 W Servomotors

Items		Specifications		External Dimensions mm	
Order No.	JZSP-CSM9-3-E (Cables are not included.)				
Applicable Servomotors	SGMJV-08A				
Manufacturer	J.S.T. Mfg. Co., Ltd.				
Receptacle	J37-06FMH-8KL-1-CF				
Cable Type	Standard				
Electrical Contact	SJ3F-41GF-P1.8 (For power terminals)	SJ3F-01GF-P1.8 (For brake terminals)			
Applicable Wire Size	AWG16 to 20	AWG20 to 24			
Outer Diameter of Insulating Sheath	1.53 dia. to 2.5 dia. mm	1.11 dia. to 1.86 dia. mm			
Crimp Tool	Hand tool	YRF-880			YRF-881
	Applicator	APLMK SF3F/M-41-20			APLMK SF3F/M-01-20
Mounting Screw	M2.5 Pan-head screw				
Applicable Cable Outer Diameter	8±0.3 dia. mm				

Selecting Cables

(6) Cable Specifications: For 50 to 400 W Servomotors

Items	Standard Type	Flexible Type
Order No.*	JZSP-CSM90-□□-E (50 m max.)	JZSP-CSM80-□□-E (50 m max.)
Specifications	UL2517 (Max. operating temperature: 105°C) AWG20×6C For power line: AWG20 (0.52 mm ²) Outer diameter of insulating sheath: 1.53 dia. mm For holding brake line: AWG20 (0.52 mm ²) Outer diameter of insulating sheath: 1.53 dia. mm	UL2517 (Max. operating temperature: 105°C) AWG22×6C For power line: AWG22 (0.33 mm ²) Outer diameter of insulating sheath: 1.37 dia. mm For holding brake line: AWG22 (0.33 mm ²) Outer diameter of insulating sheath: 1.37 dia. mm
Finished Dimensions	7±0.3 dia. mm	
Internal Configuration and Lead Color		
Yaskawa Standard Specifications (Standard Length)	Cable length: 5 m, 10 m, 15 m, 20 m, 30 m, 40 m, 50 m	

*: Specify the cable length in □□ of order no.
 Example: JZSP-CSM90-05-E (5 m)

(7) Cable Specifications: For 750 W Servomotors

Items	Standard Type	Flexible Type
Order No.*	JZSP-CSM91-□□-E (50 m max.)	JZSP-CSM81-□□-E (50 m max.)
Specifications	UL2517 (Max. operating temperature: 105°C) AWG16×4C, AWG20×2C For power line: AWG16 (1.31 mm ²) Outer diameter of insulating sheath: 2.15 dia. mm For holding brake line: AWG20 (0.52 mm ²) Outer diameter of insulating sheath: 1.6 dia. mm	UL2517 (Max. operating temperature: 105°C) AWG16×4C, AWG22×2C For power line: AWG16 (1.31 mm ²) Outer diameter of insulating sheath: 2.35 dia. mm For holding brake line: AWG22 (0.33 mm ²) Outer diameter of insulating sheath: 1.37 dia. mm
Finished Dimensions	8±0.3 dia. mm	
Internal Configuration and Lead Color		
Yaskawa Standard Specifications (Standard Length)	Cable length: 5 m, 10 m, 15 m, 20 m, 30 m, 40 m, 50 m	

*: Specify the cable length in □□ of order no.
 Example: JZSP-CSM91-05-E (5 m)

Selecting Cables

● Encoder Cables (Length: 20 m or less)

Name	Length	Order No.		Specifications	Details
		Standard Type	Flexible Type*		
Cable with Connectors (For Incremental Encoder)	3 m	JZSP-CSP01-03-E	JZSP-CSP21-03-E		(1)
	5 m	JZSP-CSP01-05-E	JZSP-CSP21-05-E		
	10 m	JZSP-CSP01-10-E	JZSP-CSP21-10-E		
	15 m	JZSP-CSP01-15-E	JZSP-CSP21-15-E		
	20 m	JZSP-CSP01-20-E	JZSP-CSP21-20-E		
Cable with Connectors (For Absolute Encoder, with a Battery Case)	3 m	JZSP-CSP05-03-E	JZSP-CSP25-03-E		(2)
	5 m	JZSP-CSP05-05-E	JZSP-CSP25-05-E		
	10 m	JZSP-CSP05-10-E	JZSP-CSP25-10-E		
	15 m	JZSP-CSP05-15-E	JZSP-CSP25-15-E		
	20 m	JZSP-CSP05-20-E	JZSP-CSP25-20-E		
SERVOPACK-end Connector Kit		JZSP-CMP9-1-E		Soldered 	(3)
Encoder-end Connector Kit		JZSP-CSP9-2-E		Crimping Type (A crimping tool is required) 	
Cables	3 m	JZSP-CMP09-03-E	JZSP-CSP39-03-E		(4)
	5 m	JZSP-CMP09-05-E	JZSP-CSP39-05-E		
	10 m	JZSP-CMP09-10-E	JZSP-CSP39-10-E		
	15 m	JZSP-CMP09-15-E	JZSP-CSP39-15-E		
	20 m	JZSP-CMP09-20-E	JZSP-CSP39-20-E		

*: Use flexible cables for movable sections such as robot arms.

Note: When the battery from the host controller is used for the absolute encoder, no battery case is required. In this case, use a cable for the incremental encoders.

(1) Wiring Specifications for Cable with Connectors
(For incremental encoder)

• Standard Type

Pin No.	Signal	Pin No.	Wire Color
6	/PS	5	Light blue/white
5	PS	4	Light blue
4	BAT (-)	8	Orange/white
3	BAT (+)	9	Orange
2	PG 0V	3	Black
1	PG 5V	6	Red
Shell	FG	Shell	FG

• Flexible Type

Pin No.	Signal	Pin No.	Wire Color
6	/PS	5	Black/pink
5	PS	4	Red/pink
4	BAT (-)	8	Black/light blue
3	BAT (+)	9	Red/light blue
2	PG 0V	3	Green
1	PG 5V	6	Orange
Shell	FG	Shell	FG

(2) Wiring Specifications for Cable with Connectors
(For absolute encoder, with a battery case)

• Standard Type

Pin No.	Signal	Pin No.	Wire Color
6	/PS	5	Light blue/white
5	PS	4	Light blue
4	BAT (-)	8	Orange/white
3	BAT (+)	9	Orange
2	PG 0V	3	Black
1	PG 5V	6	Red
Shell	FG	Shell	FG

Battery Case	
Pin No.	Signal
2	BAT (-)
1	BAT (+)

• Flexible Type

Pin No.	Signal	Pin No.	Wire Color
6	/PS	5	Black/pink
5	PS	4	Red/pink
4	BAT (-)	8	Black/light blue
3	BAT (+)	9	Red/light blue
2	PG 0V	3	Green
1	PG 5V	6	Orange
Shell	FG	Shell	FG

Battery Case	
Pin No.	Signal
2	BAT (-)
1	BAT (+)

Selecting Cables

(3) SERVOPACK-end/Encoder-end Connector Kit Specifications

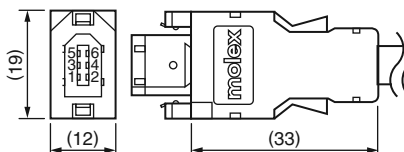
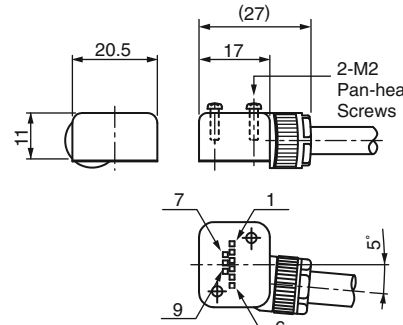
Items	SERVOPACK-end Connector Kit	Encoder-end Connector Kit
Order No.	JZSP-CMP9-1-E (Cables are not included.)	JZSP-CSP9-2-E (Cables are not included.)
Manufacturer	Molex Japan Co., Ltd.	Molex Japan Co., Ltd.
Specifications	55100-0670 (soldered)	54346-0070 (crimped)* Mounting screw: M2 pan-head screw (× 2) Applicable cable outer diameter of applicable cable: 6.3 dia. to 7.7 dia. mm Applicable wire size: AWG22 to 26 Outer diameter of insulating sheath: 1.05 dia. to 1.4 dia. mm
External Dimensions (Units: mm)		

*: A crimp tool is required.

The following crimp tools are applicable for the cables provided by Yaskawa. When using other wire sizes, contact the respective manufacturer for crimp tools.

Applicable crimp tool for Yaskawa's wire size: Hand Tool Model No. 57175-5000

Applicator Model No. 57175-3000

(4) Cable Specifications

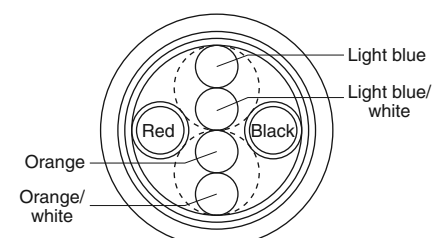
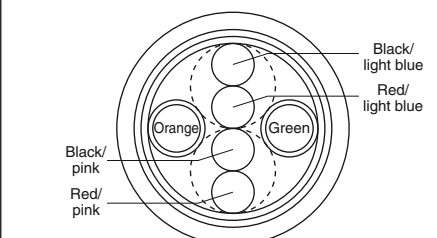
Items	Standard Type	Flexible Type
Order No.*	JZSP-CMP09-□□-E	JZSP-CSP39-□□-E
Cable Length	20 m max.	
Specifications	UL20276 (Max. operating temperature: 80°C) AWG22×2C+AWG24×2P AWG22 (0.33 mm ²) Outer diameter of insulating sheath: 1.15 dia. mm AWG24 (0.20 mm ²) Outer diameter of insulating sheath: 1.09 dia. mm	UL20276 (Max. operating temperature: 80°C) AWG22×2C+AWG24×2P AWG22 (0.33 mm ²) Outer diameter of insulating sheath: 1.35 dia. mm AWG24 (0.20 mm ²) Outer diameter of insulating sheath: 1.21 dia. mm
Finished Dimensions	6.5 dia. mm	6.8 dia. mm
Internal Configuration and Lead Color		
Yaskawa Standards Specifications (Standard Length)	Cable length: 5 m, 10 m, 15 m, 20 m	

*: Specify the cable length in □□ of order no.

Example: JZSP-CSP09-05-E (5 m)

Selecting Cables

● Relay Encoder Cables (For extending from 30 to 50 m)

Name	Length	Order No.	Specifications	Details
		Standard Type		
① Encoder-end Cables (For incremental and absolute encoder)	0.3 m	JZSP-CSP11-E		(1)
② Cable with Connectors (For incremental and absolute encoder)	30 m	JZSP-UCMP00-30-E		(2)
	40 m	JZSP-UCMP00-40-E		
	50 m	JZSP-UCMP00-50-E		
③ Cable with a Battery Case (Required when an absolute encoder is used.)	0.3 m	JZSP-CSP12-E*		(3)
④ Cables	30 m	JZSP-CMP19-30-E		(4)
	40 m	JZSP-CMP19-40-E		
	50 m	JZSP-CMP19-50-E		

*: When using an incremental encoder or using an absolute encoder with a battery connected to the host controller, no battery case is required.

(1) Wiring Specifications for Encoder-end Cable

SERVOPACK End		Encoder (Servomotor) End	
Pin No.	Signal	Pin No.	Wire Color
6	/PS	5	Light blue/white
5	PS	4	Light blue
4	BAT (-)	8	Orange/white
3	BAT (+)	9	Orange
2	PG 0V	3	Black
1	PG 5V	6	Red
Shell	FG	Shell	FG

(2) Wiring Specifications for Cable with Connectors

SERVOPACK End		Encoder (Servomotor) End	
Pin No.	Signal	Pin No.	Wire Color
6	/PS	6	Light blue/white
5	PS	5	Light blue
4	BAT (-)	4	Orange/white
3	BAT (+)	3	Orange
2	PG 0V	2	Black
1	PG 5V	1	Red
Shell	FG	Shell	FG

(3) Wiring Specifications for Cable with a Battery Case

SERVOPACK End		Encoder (Servomotor) End	
Pin No.	Signal	Pin No.	Wire Color
6	/PS	6	Light blue/white
5	PS	5	Light blue
4	BAT (-)	4	Orange/white
3	BAT (+)	3	Orange
2	PG 0V	2	Black
1	PG 5V	1	Red
Shell	FG	Shell	FG

Battery Case	
Pin No.	Signal
2	BAT (-)
1	BAT (+)

(4) Cable Specifications

Item	Standard Type
Order No.*	JZSP-CMP19-□□-E
Cable Length	50 m max.
Specifications	UL20276 (Max. operating temperature: 80°C) AWG16×2C+AWG26×2P AWG16 (1.31 mm ²) Outer diameter of insulating sheath: 2.0 dia. mm AWG26 (0.13 mm ²) Outer diameter of insulating sheath: 0.91 dia. mm
Finished Dimensions	6.8 dia. mm
Internal Configuration and Lead Colors	
Yaskawa Standard Specifications (Standard Length)	Cable length: 30 m, 40 m, 50 m

*: Specify the cable length in □□ of order no.
Example: JZSP-CMP19-30-E (30 m)